

M3100P-M3105P > STANDARD DIMENSIONS

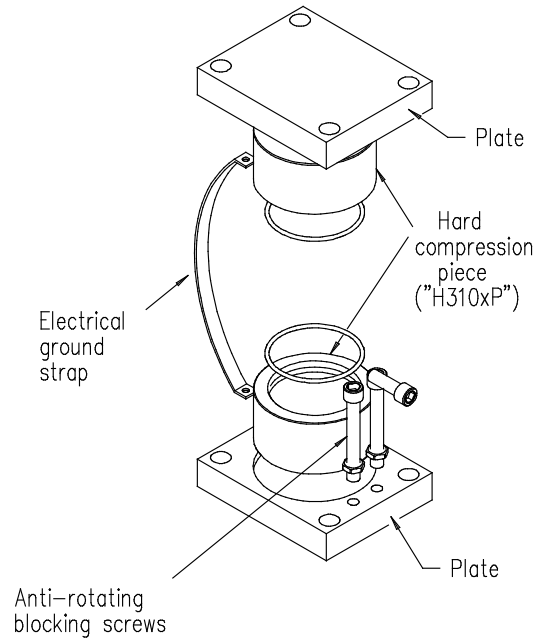
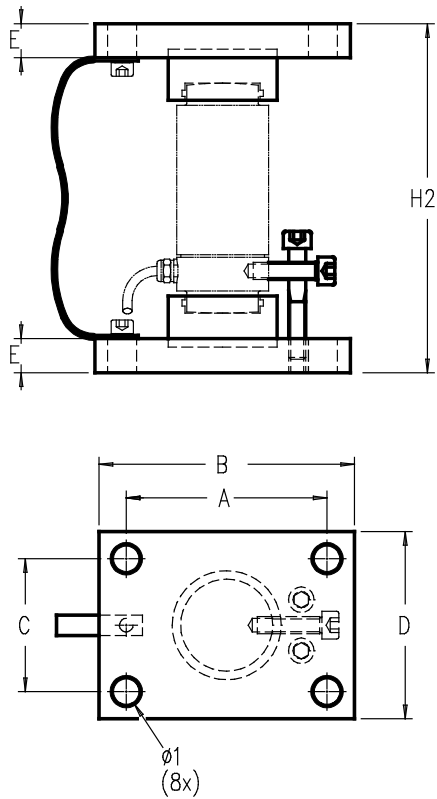

Ref. Items	Capacities	A	B	C	D	E	Ø1	H2	Weight (kg)
M310xP-A	5 - 30 t	118	150	78	110	20	17	205	±5.7
M310xP-B	50 - 100 t	130	170	90	130	30	21	294	±13
M310xP-C	150 - 200 t	185	235	135	185	40	25	370	±35.5
M310xP-D	300 t	185	235	135	185	40	25	418	±41
M310xP-E	500 t	200	260	200	260	40	27	594	±78

*x=Material: M3100P - stainless steel; M3105P - alloy steel

→ Other capacities and dimensions available on request

Dimensions in mm

Other view

