

5200-5205

TENSION LINK LOAD CELLS

Tension link load cells specially adapted for standard shackles.



Model 5205 - 25 kN



Features

- o Sturdy design
- o Protection class: IP66
- o Cable length: see drawing table - CL (other lengths available on request)
- o Material: stainless steel (5200), nickel-plated steel (5205)

Most popular options



Ex i



IP67
MARINE

Application(s) SENSY's load cells 5200-5205 are perfectly designed for the following applications:

- Tension force measurement,
- Suspended industrial weighing,
- Winch monitoring.

Capacities

5200-5205 FORCE: from 75 kN to 5 MN

5200-5205 HOIST: from 7.5 t to 500 t

Specifications	0.5 %	
Combined error (non-linearity + hysteresis)	< ± 0.5	% F.S.*
Repeatability error	< ± 0.25	% F.S.*
Creep error over 30 min.	< ± 0.2	% F.S.*
Zero shift after loading	< ± 0.1	% F.S.*
Reference temperature	23	°C
Compensated temperature range	-10...+45	°C
Service temperature range	-25...+70	°C
Storage temperature range	-50...+85	°C
Temperature coefficient of the sensitivity	< ± 0.1	% F.S.* / 10°C
Temperature coefficient of zero signal	< ± 0.1	% F.S.* / 10°C
Zero balance	± 0.02	mVV
Input resistance	352 ± 2	ohm(s)
Output resistance	352 ± 2	ohm(s)
Insulation resistance (50 V)	> 5000	Mohm(s)
Reference excitation voltage	10	VDC
Permissible nominal range of excitation voltage	3...12	VDC
Safe load limit	150	% F.S.*
Breaking load	> 300	% F.S.*

* F.S. : Full Scale.

Specifications subject to change without notice.



ISO 9001 certified

5200-5205 > STANDARD DIMENSIONS

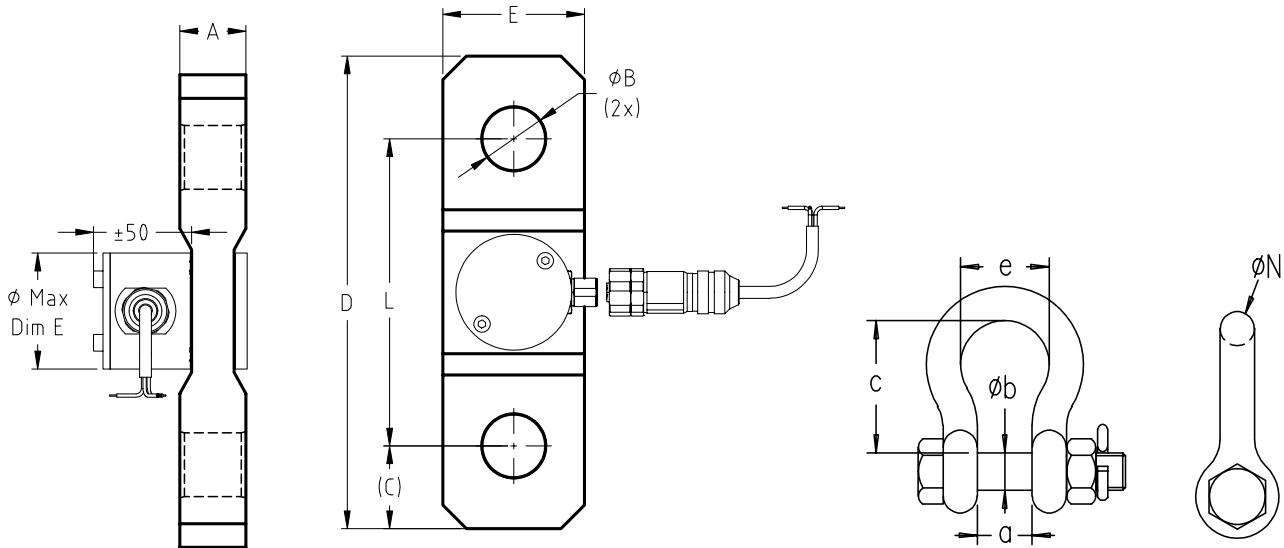

Ref. Item*	Capacities		A	Ø B	(C)	D	E	L	CL (m)	Weight (kg)
	Force	Hoist								
	> 300 %**	> 500 %**								
520x-A	75 kN	See 5200L-5205L sheet	22	27	32	179	60	115	3	2
520x-B	150 kN	See 5200L-5205L sheet	30	38	46	277	80	185	6	6
520x-C	250 kN	15 t	40	45	54	327	90	219	6	9.5
520x-D	300 kN	20 t	40	54	65	392	110	262	6	13
520x-E	500 kN	30 t	50	60	72	436	135	292	6	22
520x-F	750 kN	50 t	50	74	89	538	185	360	12	37
520x-G	1.25 MN	75 t	78	88	106	640	200	428	12	73
520x-H	1.5 MN	100 t	88	98	123	722	235	476	12	111
520x-I	2.5 MN	150 t	138	112	140	824	240	544	12	200
520x-J	3 MN	200 t	148	135	169	994	310	656	12	333
-	4 - 5 MN	400 - 500 t	According to customer's design specifications							

*x=Material: 5200 - stainless steel; 5205 - nickel-plated steel
 **Breaking load (% full scale)

S.W.L.**	ASSOCIATED SHACKLES					Ø N	
	a	Ø b	c	e	mm	inch	
	6.5 t	36±2.2	25+0.9	83±6.4	58±2.6	22+0.9	7/8"
12 t	51±3.2	35+1	115±6.4	83±4.2	32+1	1 1/4"	
17 t	60±4	42+1.5	146±6.4	99±5	38+1.5	1 1/2"	
25 t	74±4	50+2	178±6.4	126±6.3	45+2	1 3/4"	
35 t	83±4.2	57+2	197±12.7	138±7.5	50+2	2"	
55 t	105±4.7	70+2.5	260±12.7	180±9	65+2.5	2 1/2"	
85 t	127±5	83+3	329±29	190±9.5	75+3	3"	
120 t	147±5	95±2	400±19	238±12	95±2	3 3/4"	
150 t	169±5	108±2	410±12	275±14	105±2	4 1/8"	
200 t	179±5	130±3	513±13	290±15	120±3	4 23/32"	

***SWL: Safe Working Load

Other capacities and dimensions available on request

Dimensions in mm

Other views

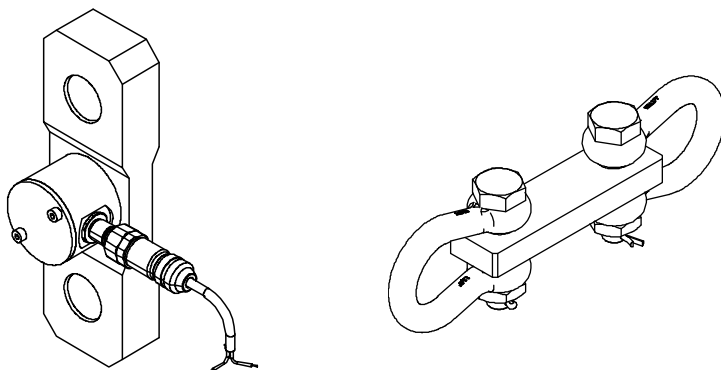

Wiring

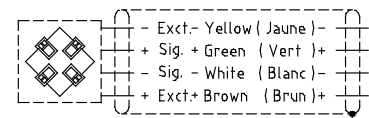

Standard : Cable screen not connected to transducer
 Faradisation non connectée au capteur

Load direction

