

5180-5182

COMPRESSION WASHER LOAD CELLS

Compression washer annular load cells specially designed for force measurement on bolts.



Model 5180 - 300 kN



Features

- o Very low profile for high-capacity load cells
- o Material:
 - stainless steel body; aluminium housing (5180)
 - anodised aluminium alloy (5182)
 - 2 washers (included): stainless steel
- o Protection class: IP65
- o Very competitive prices
- o Cable length: see drawing table - CL (other lengths available on request)

Most popular options



Ex i

Application(s) SENSY's load cells 5180-5182 are perfectly designed for the following applications:

- Bolts tightening measurement,
- Industrial force measurement in confined spaces.

Capacities

5182: 20 - 30 kN
 5180: 50 - 75 - (100) - 150 - 200 - 300 - 500 - 750 kN

Specifications	SL	
Reference temperature	23	°C
Compensated temperature range	-10...+45	°C
Service temperature range	-30...+70	°C
Storage temperature range	-50...+85	°C
Temperature coefficient of the sensitivity	<± 0.2	% F.S.* / 10°C
Temperature coefficient of zero signal	<± 0.2	% F.S.* / 10°C
Zero balance	± 0.02	mV/V
Input resistance	700 ± 2	ohm(s)
Output resistance	700 ± 2	ohm(s)
Insulation resistance (50 V)	> 5000	Mohm(s)
Reference excitation voltage	5	VDC
Permissible nominal range of excitation voltage	3..10	VDC
Safe load limit	150	% F.S.*
Breaking load	> 300	% F.S.*
Permissible dynamic loading	50	% F.S.*
Static lateral force limit	25	% F.S.*

* F.S. : Full Scale.
 Specifications subject to change without notice.

5180-5182 > STANDARD DIMENSIONS

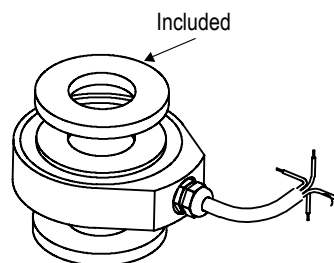
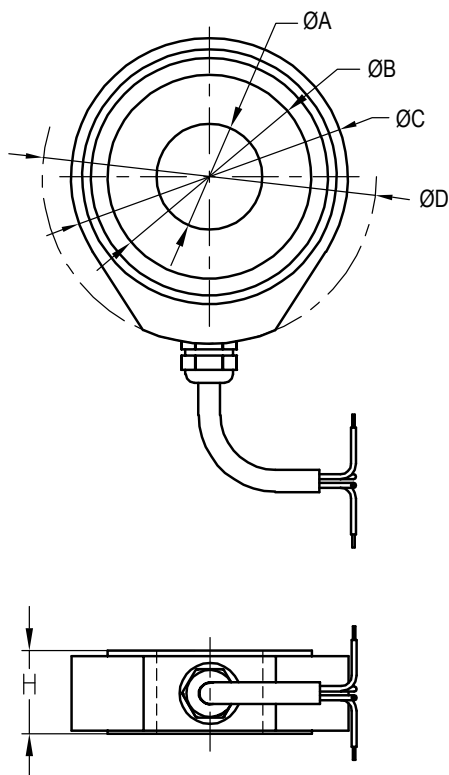

Ref. Item	Capacities	M	ØA	ØB	ØC	ØD	ØE	H	E	CL (m)	Weight(kg)
5182-A *	20 kN	6	6.1	17	34	40	12.7	11	3	2	0.1
5182-B *	30 kN	8	8.1	19.5	34	40	19	11	3	2	0.1
5180-C	50 kN	10	10.1	19.5	34	40	22	11	3	2	0.1
5180-D	75 kN	12	12.1	24	38	47	25	12.5	3	2	0.1
5180-E	150 kN	16	16.1	29	45	55	32	15	5	3	0.12
5180-F	200 kN	20	20.1	36	53	62	38	17	5	3	0.15
5180-G	300 kN	24	24.1	44.9	63	70	48	19	5	3	0.25
5180-H	500 kN	30	30.25	53	70	79	54	26	6	3	0.5
5180-I	750 kN	36	36.5	76	99	99	74	35	6	3	1.3

*: Aluminium models limited to + 130°

→ Other capacities and dimensions available on request

Dimensions in mm

Other views

The minimum roughness of mating surfaces has to be

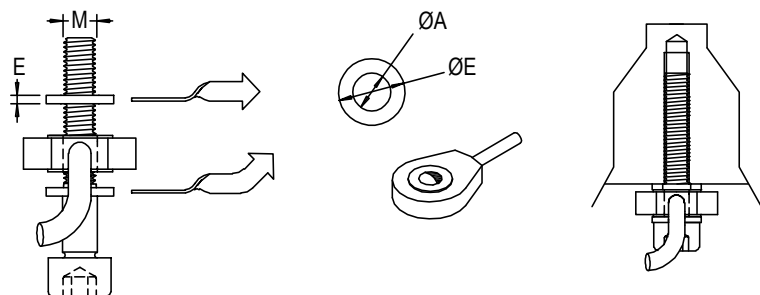
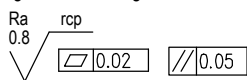

Wiring

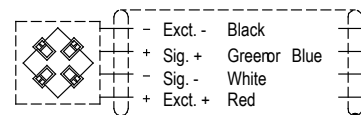

Standard: Cable screen not connected to the transducer

Load direction

